



## BUCKET ELEVATOR E50-70-100

## E50-70-100

**ALBINBİLEK Bucket Elevator** is designed for upward transport of powder and grain products in an undamaged manner. It has a completely closed and impermeable structure. It consists of an upper boot where feeding is made, a vertical tubing, and a lower boot.

### FEATURES

- Rubber Coated Driving Drum
- Mechanical Bucket Lock
- Screwed Belt Tensioning System
- Feeding from Both Sides
- Replaceable Wear Plates on Product Contact Surfaces
- Impermeable Shaft Seals
- Heavy Duty Block Bearings
- Articulated Upper Boot for Maintenance

### DRIVE SYSTEM

- Mountable Drive System at Right or Left
- Power Transmission with Belt-Pulley Connection (Standard)
- Hollow shaft for reducer motor (Optional)
- Full shaft for reducer motor and Coupling (Optional)

### SECURITY SYSTEM

- Speed Sensor (Standard)
- Upper Boot Blast Chimney (Standard)
- Tube Explosion Caps (Standard)
- Belt Slide Sensor (Optional)
- Roller Heat Detection Sensor (Optional)
- Roller Pulse Detection Sensor (Optional)

### ACCESSORIES

- Easy to Open Maintenance, Inspection, and Cleaning Covers
- Inlet Module
- Outlet Module
- Grid Lower Boot Drum (Optional)
- Plate Magnet at the Feeding Section (Optional)
- Local Filter at the Tube Section (Optional)
- Transparent Observation Hatch (Standard)

### TECHNICAL SPECIFICATIONS

Machine	E50	E70	E100
Maximum Capacity	70m <sup>3</sup> /h	100m <sup>3</sup> /h	135m <sup>3</sup> /h
Maximum Belt Speed	2.50m/s	2.50m/s	2.80m/s
Drive System	According to the application		
Sound Level	70-85 dB		
Operating Conditions	-15°C ÷ 40°C ambient temperature		

### MATERIALS

Body	Standard	Galvanized Steel and Hot Dipped Galvanized Coating
	Optional	Stainless Painted (Carbon Steel)
Wear Plates	Standard	Plastic
	Optional	Hardox
Belt	Standard	Antistatic
	Optional	Antistatic Nitril (Oil Resistant) Food Compliant (FDA Approved)
Bucket	Standard	Plastic (TAPCO)
	Optional	Steel Stainless Steel

### COMPATIBILITY

ATEX	Standard	Out of Zone
	Optional	Zone 22 - 21

NOTE: ATEX compatibility requires special requirements.



## BUCKET ELEVATOR E50-70-100

## E50-70-100

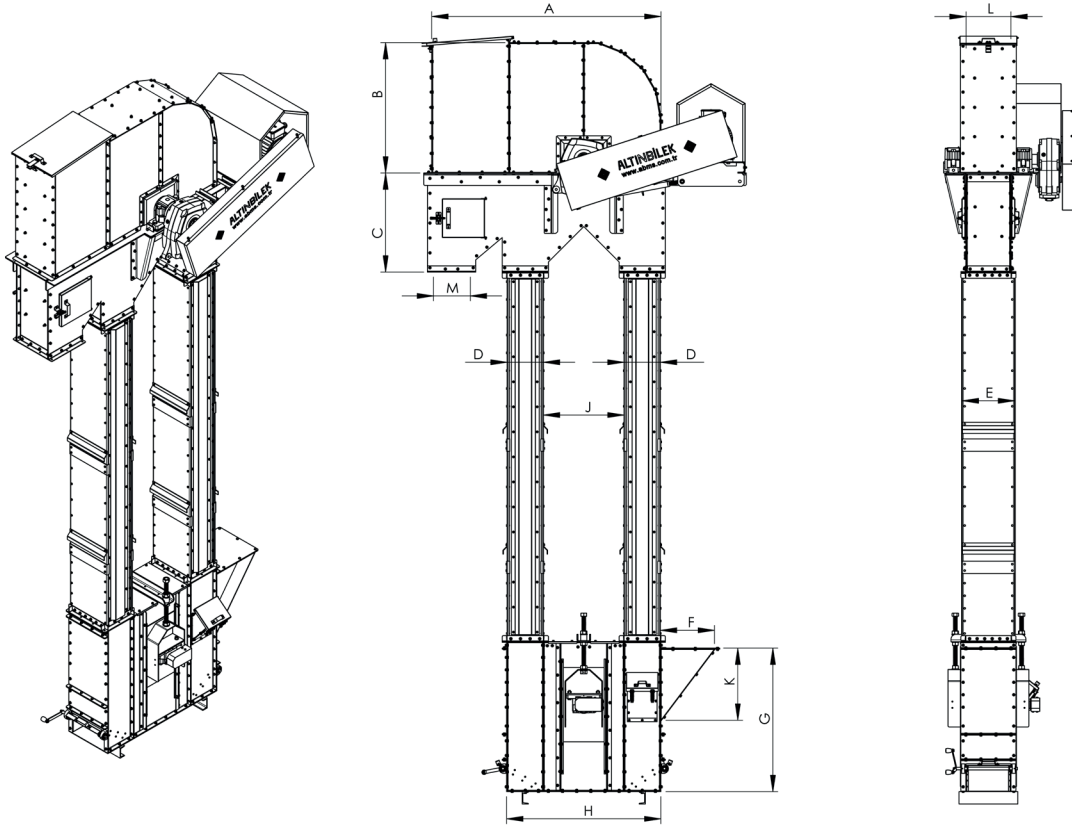

MODEL	A(mm)	B(mm)	C(mm)	D(mm)	E(mm)	F(mm)	G(mm)	H(mm)	J(mm)	K(mm)	L(mm)	M(mm)
E50	1465	625	640	235	330	400	1000	940	465	515	280	247x264
E70	1465	625	640	235	330	400	1000	940	465	515	280	247x264
E100	1720	760	725	285	390	450	1160	1110	540	585	340	334x322

Designs and dimensions are subject to change without notice.