



## PADDLE SWEEP

**ALTINBILEK**, Paddle Sweep ensures that granular raw materials such as wheat, corn, sunflower, canola, and paddy remaining in the areas close to the bottom after natural flow in the flat bottom silo are conveyed to the center flow - point without damage and quickly. It permorms the discharge process by rotating 360° inside the silo. It is also preferable in horizontal warehouse discharge applications. Tracked sweep auger conveys product by the help of its flexible crawlers to the discharge point without any damage. Since it sweeps closer to the bottom than other augers during the operation, it offers a clean bottom. It has highly quality components and a durable body structure. The movement is driven by a single motor. It is easy to operate and requires less maintenance.

### FEATURES

- Completely Bolted Joint,
- Easy Assembly, Maximum Endurance
- Heat-treated Rotary Api Type Chain
- Bolt-fixed Rubber Pallets in the Chain
- Manual Screwed Tensioning System
- Maximum Bottom Cleaning Performance
- Track and Adjustable Drive Wheels compatible with the ground
- Rubber Coated Propelling Wheels
- Electric Conduction System (Slipping)

### DRIVE SYSTEM

- Reducer motor (Standard)

### ACCESSORIES

- Bearer Legs with Height Adjustment
- Capacity Adjustment Flaps
- Bearer Lever Jack Supports
- Motor Housing

### SECURITY SYSTEM

- Location Sensor (Optional)

## TECHNICAL SPECIFICATIONS

Machine	:	PTS200	PTS250	PTS300	PTS350	PTS400	PTS450
Maximum Capacity	:	230m <sup>3</sup> /h	240m <sup>3</sup> /h	266m <sup>3</sup> /h	333m <sup>3</sup> /h	466m <sup>3</sup> /h	533m <sup>3</sup> /h
Drive System	:	Reducer Motor					
Driver System	:	Reducer (Standard)		Reducer motor (Optional)			
Operating Conditions	:	-15°C ÷ 40°C ambient temperature					

## MATERIALS

Body	:	Standard	Painted (Carbon Steel)
	:	Optional	Galvanized Steel and Hot Dipped Galvanized Coating
Chain	:	Standard	Steel (Heat-treated)
Scrapper Pallet	:	Standard	Rubber



## DIMENSIONS OF PADDLE SWEEP

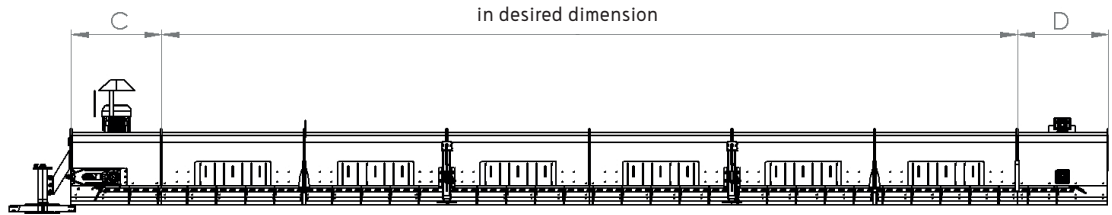
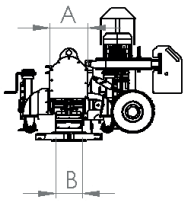
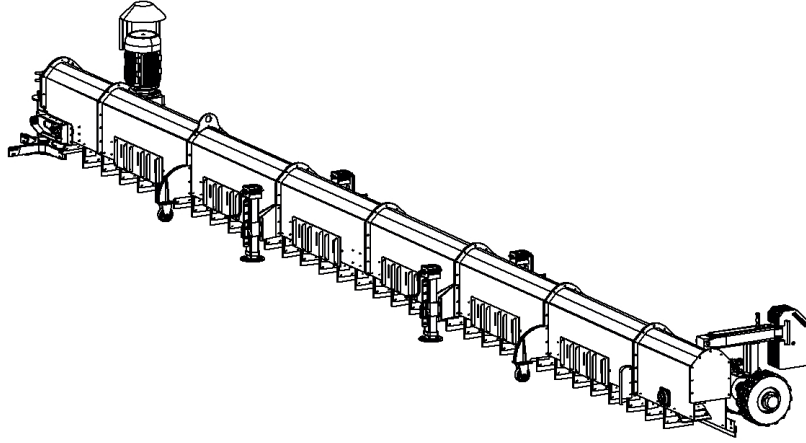

MODEL	Capacity (m <sup>3</sup> /h)	A (mm)	B (mm)	C (mm)	D (mm)
PTS200	200	296	200	950	950
PTS250	266	346	250	950	950
PTS300	320	396	300	950	950
PTS350	370	446	350	950	950
PTS400	466	496	400	1000	940
PTS450	533	566	450	1000	790

Designs and dimensions are subject to change without notice.