

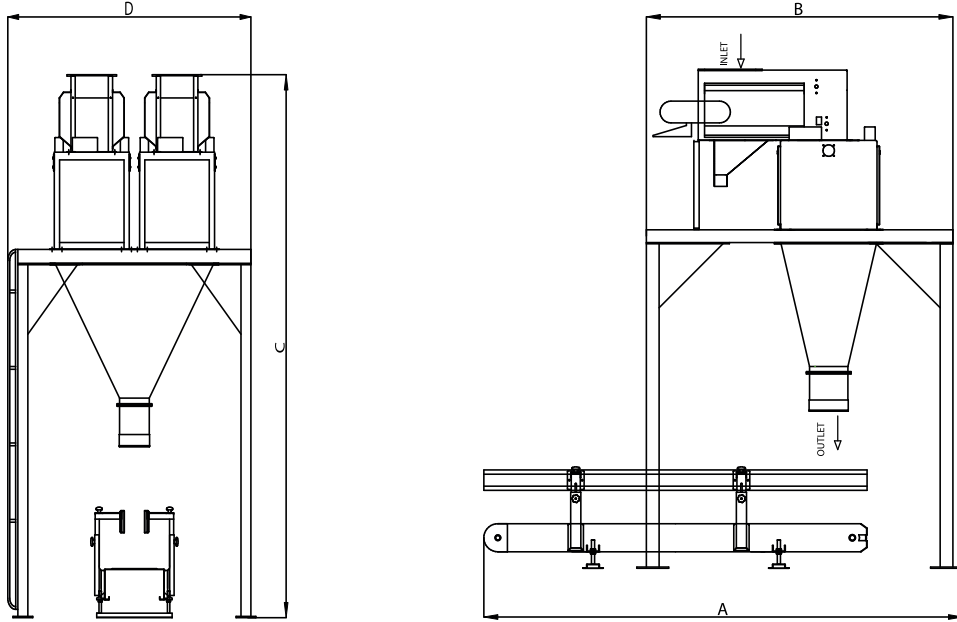

BAGGING SCALE- DOUBLE PAN

ALTINBİLEK Bagging Scales are industrial machines that provide precise and serial weighing of raw materials and products in powder, flake or pellet form at desired capacities in the range of 10-50 kg. Altinbilek Bagging Scales has a wide range of products including single scale, double scale, belt feed, screw feed and free flow. It has a working system that automatically weighs raw materials or products and discharges into the bag within its own automatic period. Set values such as weight and number of bags can be entered by the operator on the control panel. Charging / batch system is used in the weighing process. While calculating the capacity of the system, the weighing amount and the number of charges/batches per unit time are very important. Electronic load cell suitable for weight and construction is used for weighing. We customize our designs in accordance with your system, taking into account raw materials with different particle sizes, specific gravities and different flow characteristics. The perfect harmony of mechanics and electronics is provided for accurate and precise weighing. Altinbilek Bagging Scales provide ease of transportation and installation with their modular structure as well as their rigidity. There are height adjustment and sack tilting mechanisms on the belt conveyor where the packaged products are transported after the weighing process. The embouchures of the packaged products are sewn quickly and easily with the sewing machine. The vertical height of the sewing machine can be adjusted easily with the rack gear movement system.



BAGGING SCALE

MODEL Type	Number of Pans	Motor Power (kW x Adet)	ÖLÇÜLER / Dimensions (mm)				Explanation
			A	B	C	D	
TKBT	1	1,5x1	3740	2370	3670	1900	Belt Feeding
TKBC	2	1,5x2	3750	2400	3910	2450	Belt Feeding
TKST	1	-	3740	2370	3670	1900	Free Fowing
TKSC	2	-	3750	2400	3910	2450	Free Fowing

The designs and dimensions may be modified without notice.