



BUCKET ELEVATOR E800-1000-1200

E800-1000-1200

ALTINBILEK Bucket Elevator is designed for upward transport of powder and grain products in an undamaged manner. It has a completely closed and impermeable structure. It consists of an upper boot where feeding is made, a vertical tubing, and a lower boot.

FEATURES

- Rubber Coated Driving Drum
- Mechanical Bucket Lock
- Weighted Belt-Tensioning System
- Feeding from Both Sides
- Replaceable Wear Plates on Product Contact Surfaces
- Impermeable Shaft Seals
- Heavy Duty Block Bearings
- Articulated Upper Boot for Maintenance

DRIVE SYSTEM

- Mountable Drive System at Right or Left
- Power Transmission with Belt-Pulley Connection (Standard)
- Hollow shaft for reducer motor (Optional)
- Full shaft for reducer motor and Coupling (Optional)
- Industrial Reducer with Auxiliary Drive (Optional)

SECURITY SYSTEM

- Speed Sensor (Standard)
- Upper Boot Blast Chimney (Standard)
- Tube Explosion Caps (Standard)
- Belt Slide Sensor (Optional)
- Roller Heat Detection Sensor (Optional)
- Roller Pulse Detection Sensor (Optional)

ACCESSORIES

- Easy to Open Maintenance, Inspection, and Cleaning Covers
- Inlet Module
- Outlet Module
- Grid Lower Boot Drum (Optional)
- Plate Magnet at the Feeding Section (Optional)
- Local Filter at the Tube Section (Optional)
- Transparent Observation Hatch (Standard)

TECHNICAL SPECIFICATIONS

Machine	E800	E1000	E1200
Maximum Capacity	1060m ³ /h	1380m ³ /h	1650m ³ /h
Maximum Belt Speed	3.20m/s	3.20m/s	3.20m/s
Drive System	According to the application		
Sound Level	70-85 dB		
Operating Conditions	-15°C ÷ 40°C ambient temperature		

MATERIALS

Body	Standard	Galvanized Steel and Hot Dipped Galvanized Coating
	Optional	Stainless Painted (Carbon Steel)
Wear Plates	Standard	Plastic
	Optional	Hardox
Belt	Standard	Antistatic
	Optional	Antistatic Nitril (Oil Resistant) Food Compliant (FDA Approved)
Bucket	Standard	Plastic (TAPCO)
	Optional	Steel Stainless Steel

COMPATIBILITY

ATEX	Standard	Out of Zone
	Optional	Zone 22 - 21

NOTE: ATEX compatibility requires special requirements.



BUCKET ELEVATOR E800-1000-1200

E800-1000-1200

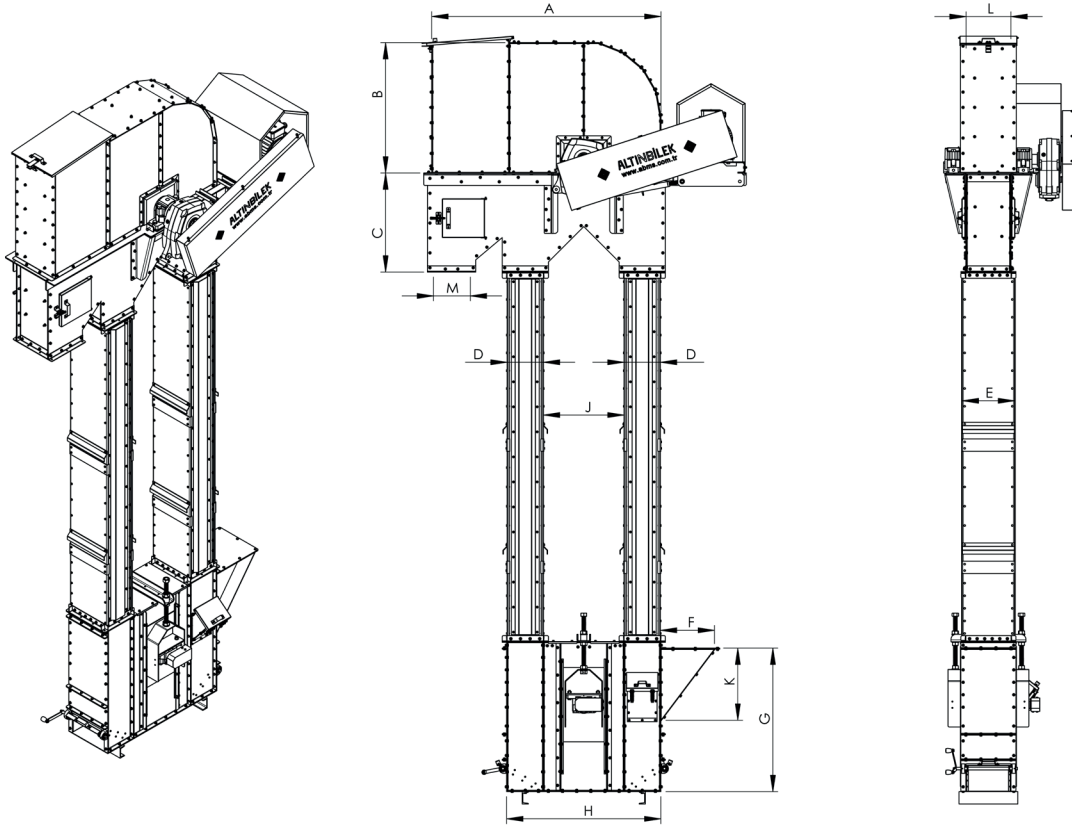

MODEL	A(mm)	B(mm)	C(mm)	D(mm)	E(mm)	F(mm)	G(mm)	H(mm)	J(mm)	K(mm)	L(mm)	M(mm)
E800	3075	1400	1385	400	1475	780	1845	1885	1095	1040	1355	695x1330
E1000	3075	1400	1385	400	1875	780	1845	1885	1095	1040	1755	695x1730
E1200	3075	1400	1385	400	2075	780	1845	1885	1095	1040	1955	695x2330

Designs and dimensions are subject to change without notice.